

FAN-WHEEL model

VRBC 097/240

Simple suction centrifugal fan edged



Suction



Ventilation



Smoke extraction



Heating



Professional Home appliance cooking



Air conditioning



Special uses

The innovative fan-wheel VRBC 097/240

The high-performance VRBC fan-wheel is an essential accessory for various sectors such as ventilation, suction, smoke extraction, heating, air conditioning, professional cooking, household appliances and various specialized uses. Equipped with advanced technology and high-quality materials, this fan-wheel ensures powerful and silent air circulation. With its versatility and reliability, the fan-wheel provides an effective solution for controlling the application environment. Thanks to its compact design and easy installation, it is suitable for a wide range of industrial applications.

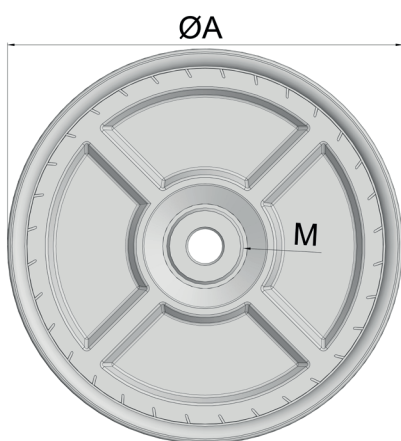

Rotational direction



	Fan Material	Zn-Al-AISI
	Diameter	Ø097 ÷ 240
H	Height	38 ÷ 118
Z	No. of blades	21 ÷ 49
	Hub Type	Chamfered-flanged
	Hub Material	FE-Al-AISI
	Balancing	G6.3 ISO 1940



Instruction Manual
Rev. 21.11.2023