

FAN-WHEEL model

VRA 160/400 airtek 2.0 ^{Patented}

Patented High-efficiency bi-directional fan, electro-tipped blades



Professional cooking



Home appliance



Special uses

The innovative patented fan-wheel Airtek 2.0

- Simple design, ideal for a Lean production
- Its weight reduction decreases the inertia, supports the reversing and lowers the energy consumption
- Improvement of the mechanical features
- Remarkable increasing of the airflow
- The ring placed in an intermediate area, divides the flow of air coming from the impeller into two distinct sections, creating a specific, shielded area suitable for measuring the temperature of the flow of air sucked
- The air acceleration given by the position of the ring generates a depression in the back side of the impeller

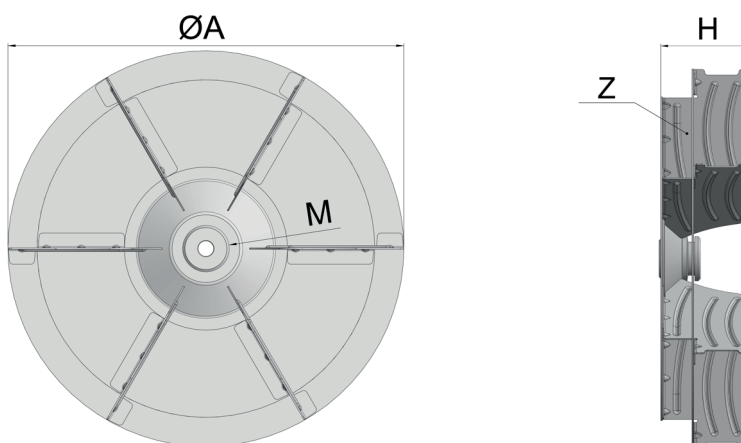

Rotational direction



	Fan Material	AISI304-316-430
	Diameter	Ø160 ÷ 400
H	Height	30 ÷ 127
Z	No. of blades	6 ÷ 8
	Hub Type	Single-double chamfering + MIG welding
	Hub Material	AISI 303-304-316
	Balancing	G6.3 ISO 1940



Instruction Manual
Rev. 21.11.2023

airteK efficiency

 **ma.ti.ka.**[®]

Our **vision**,
your **evolution**.

Made in Italy 

matikasrl.it

